

iRobot® Command Module

OWNERS MANUAL

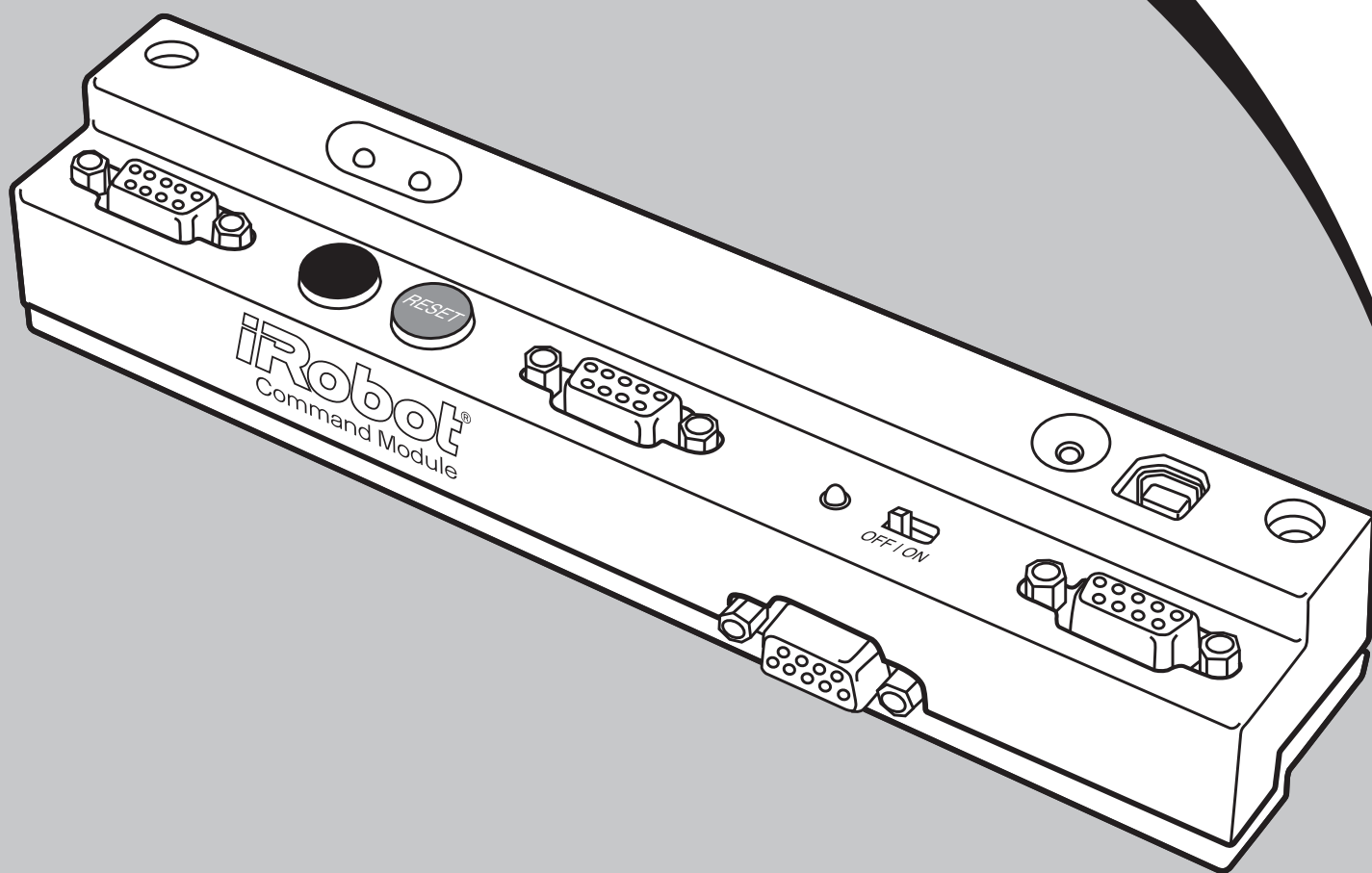

Important Safety Instructions

GENERAL SAFETY INSTRUCTIONS

- Read all safety and operating instructions before operating iRobot Command Module.
- Retain the safety and operating instructions for future reference.
- Follow all operating and use instructions.
- Refer all non-routine servicing to iRobot.

COMMAND MODULE USE RESTRICTIONS

- The Command Module is for indoor use only.
- Do not sit or stand on this device.
- Keep the switch in the off position, otherwise the Create robot battery will drain when iRobot Command Module is on.
- Do not pour or spray water onto iRobot Command Module.
- Do not expose iRobot Command Module to anything hazardous, or anything that is burning or smoking.
- iRobot Create has built-in safety sensors to keep it from falling down stairs and bumping hard into walls. iRobot is not responsible for any product issues that may arise if you disable those sensors using the Command Module.
- Never handle the Command Module with wet hands.
- Only experienced users should attempt to design and build their own circuitry.

ePort SAFETY INSTRUCTIONS

The maximum voltage available on the ePort is 21V, so the ePort pins will not shock you if they contact your skin. However, the ePort can supply over 20 watts of electrical power. In the event of an electrical fault, this can generate enough heat to burn you or start a fire in the event of an electrical fault. Only experienced users should attempt to design and build their own circuitry. Prebuilt ePort modules are available from a supplier listed in the Appendix A and are suitable for users who lack the experience to design their own circuitry.

- Always use care when wiring custom circuitry to an ePort.
- Never run your iRobot Create unattended.
- Always fully test your new designs under close supervision.
- Always remove the battery from Create or remove the ePort add-on circuitry from Create before handling it.
- Never touch the circuitry with the power turned on.
- Enclose your add-on circuitry so it is not inadvertently shorted during operation.
- The Vcc and Vpwr supplies are protected by a self-resetting fuse within Create. If you exceed the current ratings, power Create off for 30 seconds to reset the fuse.

Table of Contents

Introduction	5
1.1 Anatomy.....	5
1.2 Overview	5
1.3 Example applications	5
2. Getting Started	6
2.1 Plugging in the Command Module	6
2.2 Running the preinstalled “drive” demo program	6
2.3 Installing the development tools	7
2.4 Installing the USB serial port.....	8
3. Your First Project	10
3.1 Developing for the Command Module	10
3.2 Setting up a new project.....	10
3.3 Compiling your project.....	11
3.4 Downloading your project over the USB link	12
3.5 Testing the “input” example program.....	13
3.6 Creating your own project	14
4. Software Reference	15
4.1 Declaring and using variables and registers on the ATmega168	15
4.2 I/O Pin Basics	15
4.3 The Command Module’s connectors	15
4.4 The Digital I/O control registers	16
4.5 DDRx: Setting the direction of a pin.....	16
4.6 PORTx: Setting pullups on an input pin	16
4.7 PORTx: Setting the state of an output pin	16
4.8 PINx: Reading the state of an input or output pin	16
4.9 Using bitwise operators to selectively change bit values	17

4.10 Command Module Internal Pins	17
4.11 Adding a button and LED to the input example program	18
4.12 Taking an analog measurement using the ADC	18
4.13 Using an analog measurement in the light example program	19
4.14 Using a timer.....	20
4.15 Debouncing a Button Input	21
4.16 Setting up and using the serial port	22
4.17 Using the USB Port for Serial Debugging	23
4.18 Powering Create	23
4.19 Putting the Command Module to Sleep.....	24
5. Open Interface Reference	25
5.1 Starting the Open Interface	25
5.2 Changing the baud rate	25
5.3 Controlling Create's LEDs.....	26
5.4 Composing and playing songs.....	26
5.5 Moving Create	27
5.6 Controlling Create's low-side power drivers	27
5.7 Sending an Infrared Character	28
5.8 Reading Create's sensors	28
6. Microcontroller reference.....	29
7. Bootloader reference	30
8. Hardware reference	31
8.1 ePort Pinouts	31
8.2 ePort I/O connections.....	31
8.3 ePort connection types and interfacing.....	32
8.4 ePort electrical specifications	33
8.5 ePort safety and cautions.....	33
8.6 Component Suppliers.....	34

1 Introduction

1.1 Anatomy

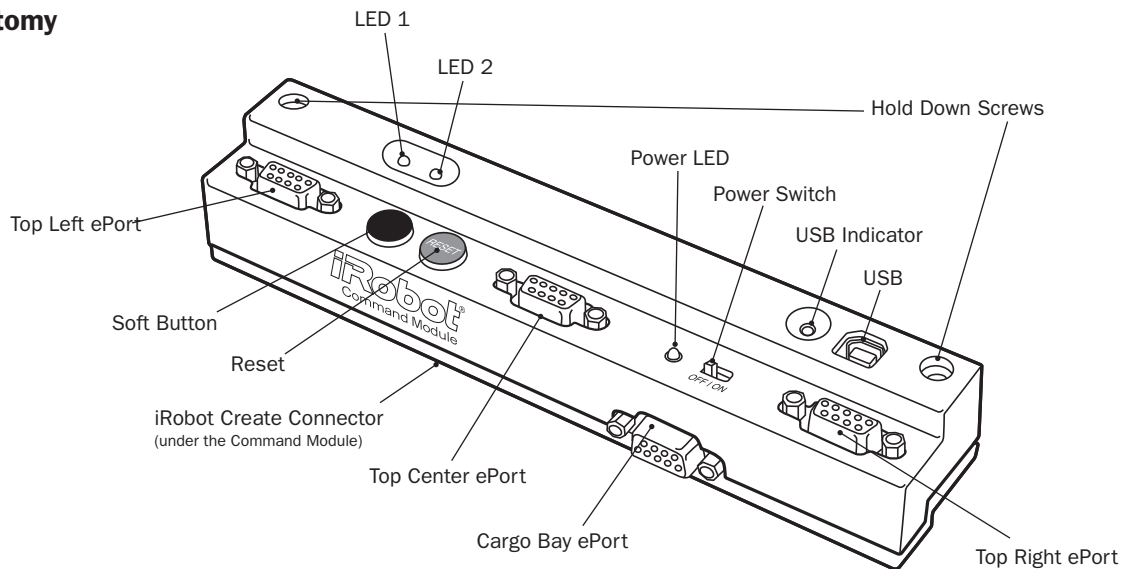

1.2 Overview

The iRobot Command Module works with iRobot Create, giving you a way to write your own programs in C or C++ to control Create and to add custom hardware to expand Create's capabilities without tethering the robot to a PC.

The Command Module plugs into Create's Cargo Bay Connector, and it has four expansion ports that provide additional inputs and outputs for your custom hardware. Three of the connectors are on the top surface, spaced to provide easy attachment points for an array of sensors, and one connector is on the back for easy access from the cargo bay.

The Command Module is powered by an Atmel AVR ATmega168 microcontroller which can be reprogrammed by downloading programs from your Windows XP computer with the included USB cable. Your programs can use the iRobot Open Interface serial protocol to control Create's motors, lights, and speaker, and read its sensors. At the same time, the microcontroller can directly interface with your own custom hardware through its I/O connections. Start with one of the example programs and expand and change it to add your own functionality. Updates and more information are available at www.irobot.com/create.

This manual assumes intermediate knowledge of the C or C++ programming languages, including bitwise operators. If you don't know either of these languages, pick up a book on C from a library or bookstore. You can also find a lot of good reference materials and tutorials online by searching for "C language" in an internet search engine.

The manual also assumes a basic familiarity with microcontrollers, including I/O pins, registers, and interrupts, as well as experience with compilers and interactive development environments (IDEs).

For more information on how to use the Command Module's software capabilities, please see the Software Reference chapter and the Open Interface reference guide found at www.irobot.com/create.

1.3 Example applications

Whether you are a hacker, educator, or robotics hobbyist, the Command Module opens many exciting possibilities. The applications are limited only by your imagination:

- Teach robotics and programming at high schools or universities. iRobot Create is a robust, affordable robotic platform that enables students to each have their own robot.
- Add new sensors and carry out your own robotics experiments.
- Create a low-cost swarm of robots to investigate collective behavior.
- Have fun with robot "art" exhibits, song and dances or other entertaining behaviors.
- Add a camera and internet connection to create a low cost sentry robot.

2 Getting Started

2.1 Plugging in the iRobot Command Module

Turn off Create.

Plug the Command Module into the Create's Cargo Bay Connector as shown in Figure 1. Make sure it is firmly seated.

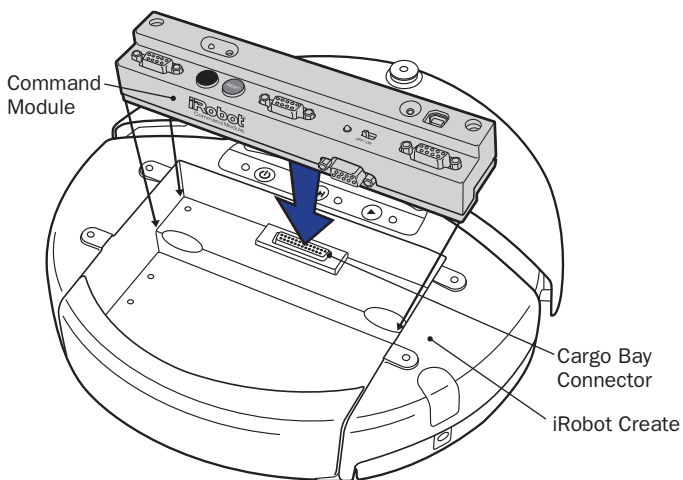

Create Figure 1 Inserting the Command Module into Create connector

Tighten the two hold-down screws on either end of the Command Module with a Phillips head screwdriver, as shown in Figure 2.

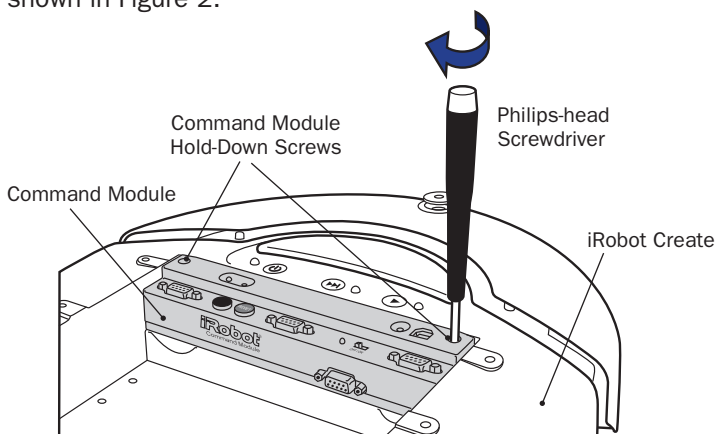

Create Figure 2 Securing the Command Module with the hold-down screws

2.2 Running the preinstalled “drive” demo program

The Command Module comes pre-installed with a demo program to let you know that everything is working.

Turn on Create and wait two seconds until Create's Power LED stops flashing, which indicates that Create is now running its main code.

Press the “reset” button on the Command Module and listen for a series of fast beeps. The LEDs on the Command Module and Create will blink slowly.

Place Create on the ground and press the black “soft” button on the Command Module. The robot will play another song and then start driving around and flashing its LEDs in sequence, beeping and turning when it bumps into something. To stop the robot, press the “soft” button again or pick the robot up.

Troubleshooting:

- After turning on Create, always wait until Create's Power LED stops flashing rapidly before starting a Command Module program.
- Make sure the Command Module is securely seated.
- Make sure that your iRobot Create has a full set of charged batteries (see Create documentation for more information on batteries).
- Disconnect the USB cable from the Command Module.
- Ensure that Create's serial cable is not connected to its Mini-DIN connector.

2.3 Installing the development tools

The development tools provided on the included CD-ROM allow you to create your own Command Module programs. The Command Module uses the WinAVR set of open-source development tools to let you write your own programs in the C or C++ languages. The development tools include an editor, compiler, and a downloader for loading your program onto the Command Module. For more information on WinAVR, please check the project website at <http://winavr.sourceforge.net>

To install WinAVR on your Windows XP computer, perform the steps below. If you have a previous version of WinAVR installed on your computer, please uninstall it before proceeding.

! NOTE: WinAVR places its access paths at the front of Window's PATH environment variable. This can cause conflicts with application that use executables or dlls that are also in WinAVR (e.g. make.exe; tcclsh84.dll). To fix this, after installing, move WinAVR's paths to the end of the PATH environment variable. Open Settings>Control Panel>System, click on Advanced, click on Environment Variables, Select Path under System Variables, click on Edit, move C:\WinAVR\utils\bin and C:\WinAVR\bin to the end of the list (after a semicolon), and click OK 3 times. On one occasion, installing WinAVR wiped out the installer's entire path. For safety, copy the value of your path variable to a spare text file in case you need to restore it later.

1. Insert the Command Module product CD into your computer. Start the WinAVR installation program (WinAVR-20060421-install.exe) by double-clicking on it.

2. Select your language.



3. Click through the rest of the install screens, accepting the defaults.



4. The last screen says that WinAVR has been installed on your computer. The installation is now complete. Click Finish.

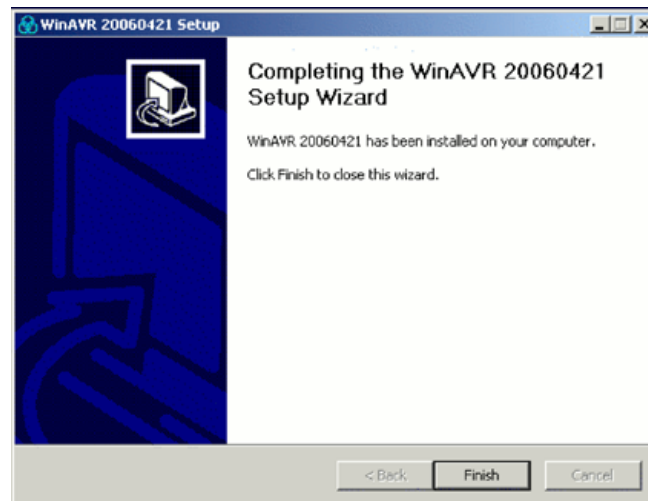

2.4 Installing the USB serial port

To install the drivers for the USB serial port, connect your Command Module to your PC using the provided USB cable as shown in Figure 3.

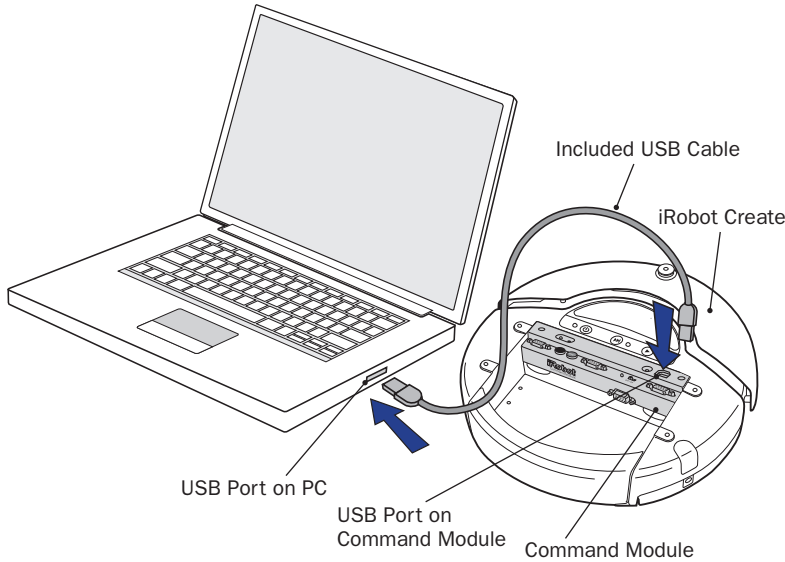

Create Figure 3 Connecting the Command Module to your computer's USB port

The Command Module should be automatically detected and the **New Hardware Wizard** window will pop up.

Select **Yes** to allow Windows to connect to Windows Update



Select the **Install the software automatically** option



It should install the driver and return without errors saying that the hardware is installed and ready to use.

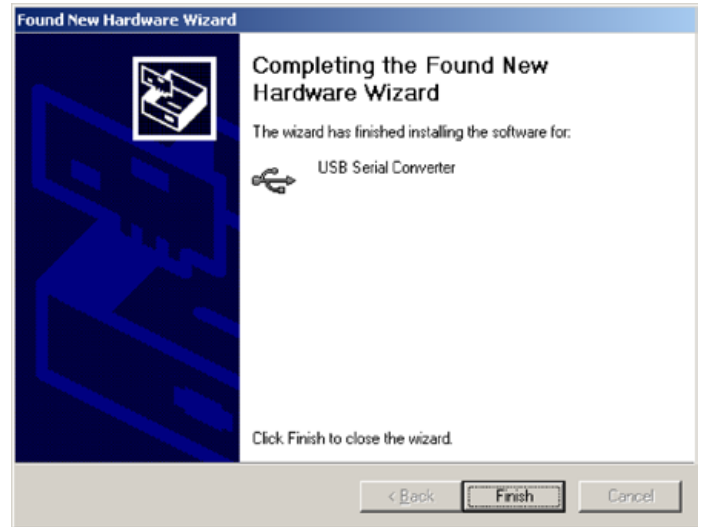

! If the wizard says that it is unable to find the software, quit the wizard and open the Command Module product CD. Install the drivers manually by double-clicking on CDM_Setup_32.exe (if you have 32-bit Windows XP) or CDM_Setup_64.exe (if you have 64-bit Windows XP).

The New Hardware Wizard window will then pop up a second time, showing that it has found a USB Serial Port. Repeat the above procedure, again selecting the Install the software automatically option. Once the driver installation has completed, click the Finish button and proceed to the next step.

Next, find the COM port number which was assigned to the Command Module.

On your PC, go to Start->Settings->Control Panel->System.

Go to the Hardware tab and click the **Device Manager** button.

Scroll down and expand the **Ports (COM & LPT)** category by clicking on the + sign.

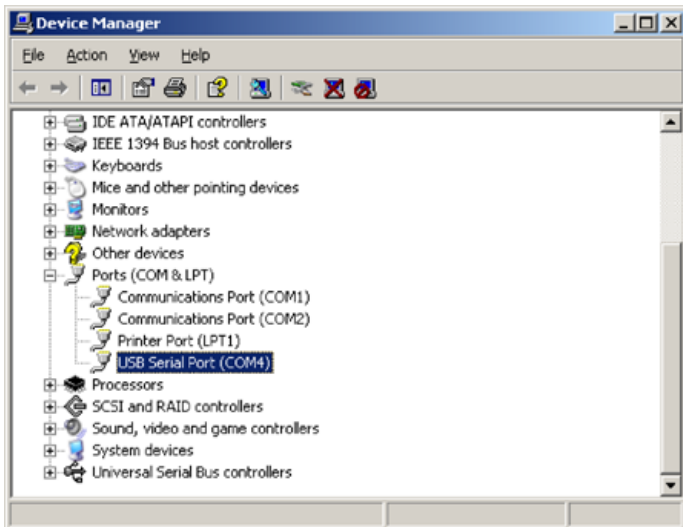

Double click on the **USB Serial Port** line to launch the properties window.

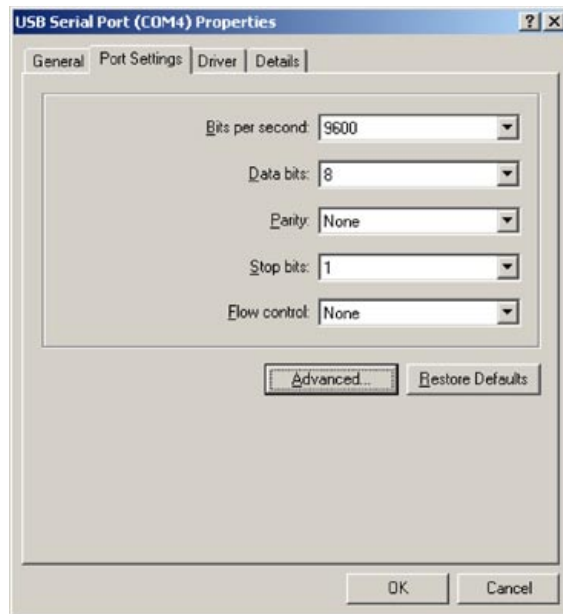

Select the **Port Settings** tab and then click on the **Advanced** button.

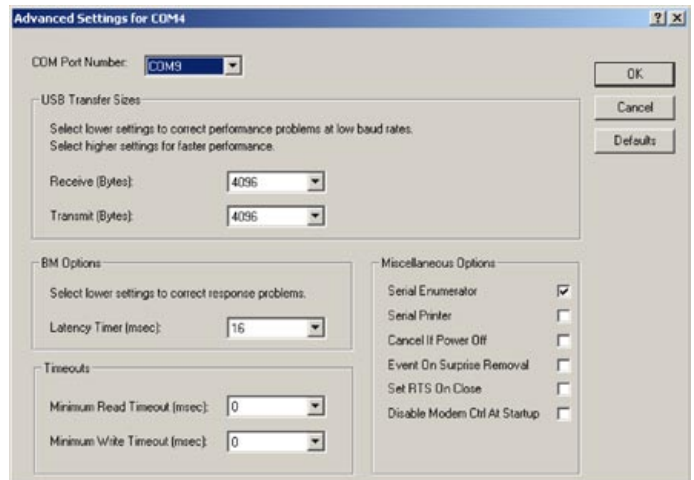

Change the **COM Port Number** to COM9 or another unused port between COM1 and COM9 using the pull-down menu. Using a high port number will reduce the chances that the port setting will interfere with other hardware that you may install on your computer in the future. All of the example programs assume that you are using COM9. If you use a COM port other than COM9, you will need to update the example program's makefile before you download to the Command Module. The installation is now complete.

3 Your First Project

The example programs are a good place to start using the Command Module. The program that came preprogrammed on your Command Module is called **drive** and its source code is in the “Sample Projects” directory on the Command Module Product CD. This chapter will guide you through compiling and downloading one of the other example programs named **input**, and will then give you directions for creating your own project. The **input** example program is designed to demonstrate how to use all of the Command Module’s input and output capabilities using buttons and LEDs.

3.1 Developing for the Command Module

The Command Module is built around an Atmel AVR ATmega168 microcontroller. All of the programs that you write and load onto the Command Module are run on this 8-bit processor. For more information on the microcontroller, please see the microcontroller reference section in chapter 7 and the microcontroller spec sheet on the Product CD.

The Command Module uses the WinAVR suite of open source development tools to compile and download your C or C++ programs. The WinAVR tools include the GNU GCC compiler, avrdude downloader, and the Programmers Notepad IDE.

The WinAVR installer installs a lot of useful documentation in the C:\WinAVR\doc directory. In the avr-libc sub-directory you’ll find the avr-libc user’s manual, which has information on many functions designed for AVR microcontrollers which you can use in your programs. Another good resource for developing with AVR microcontrollers and using WinAVR in particular is the avrfreaks website at <http://www.avrfreaks.net>. One of the best sources of information on the website is the forum, where you can find answers to most of your development questions. Be sure to search the forum before posting your own question because most common questions have already been answered already.

3.2 Setting up a new project

In this example, you will set up a new project for the **input** example program. The steps are similar for any new project you create.

1. **Get the source files.** Make a new directory on your computer and name it “input.” Copy the files input.c, oi.h, and makefile from the examples/input directory on the Command Module CD to this directory. The file input.c is the main C source code file, oi.h is the Open Interface header file, and makefile contains instructions for Programmers Notepad on how to compile and download the project.

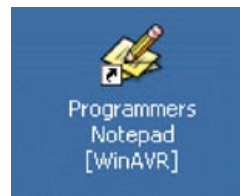

2. **Start Programmers Notepad using the desktop shortcut.** If you don’t have the shortcut, find Programmers Notepad directly at C:\WinAVR\pn\pn.exe (if you used the default installation directory)

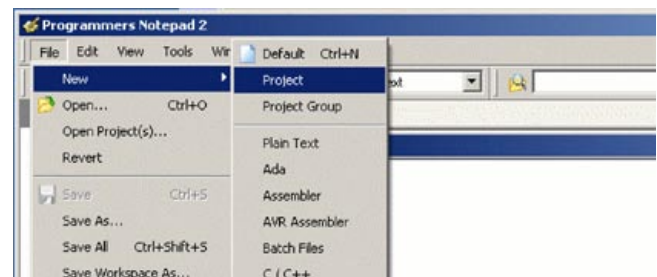

3. **Create a new project.** In Programmers Notepad, go to **File->New** and click on Project.

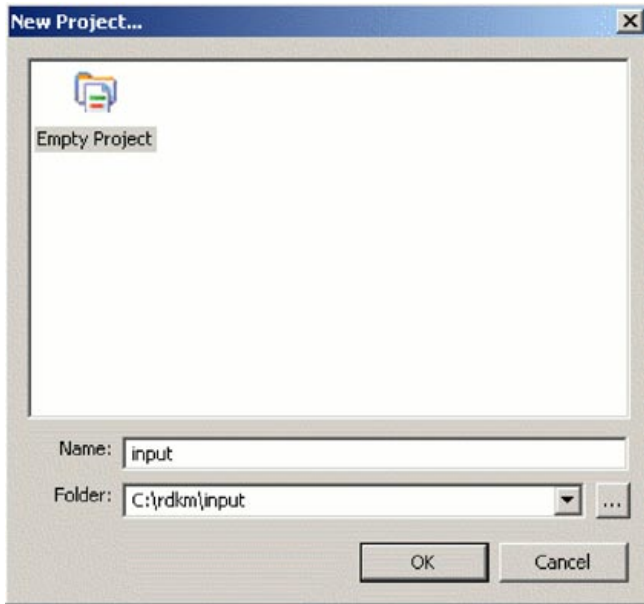

4. Click on the ... button to select the project directory where you saved the project code (in step 1). Fill in a name for your new project (such as “input”), and click the OK button.

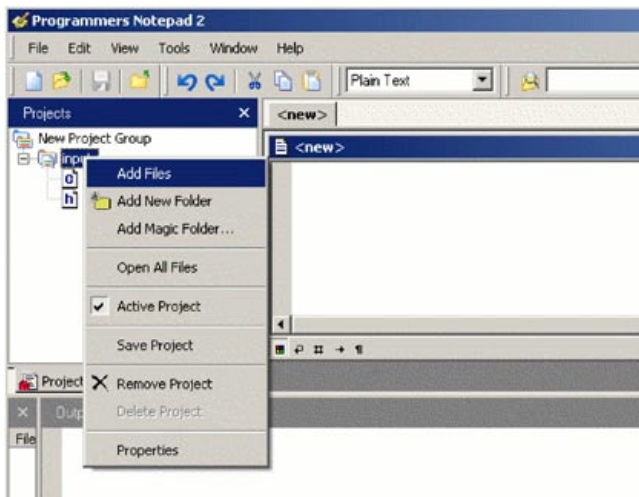

5. **Add files to your project.** Your new project should now show up in the upper left-hand window of Programmers Notepad.

Right click on the name of the project under New Project Group and select the Add Files option.

In the dialog box that opens, find your “input” project directory, select the file input.c, and click the Open button to add it to your project. The file you just added will now show up beneath the project name.

Repeat these steps to also add oi.h and makefile to your project.

3.3 Compiling your project

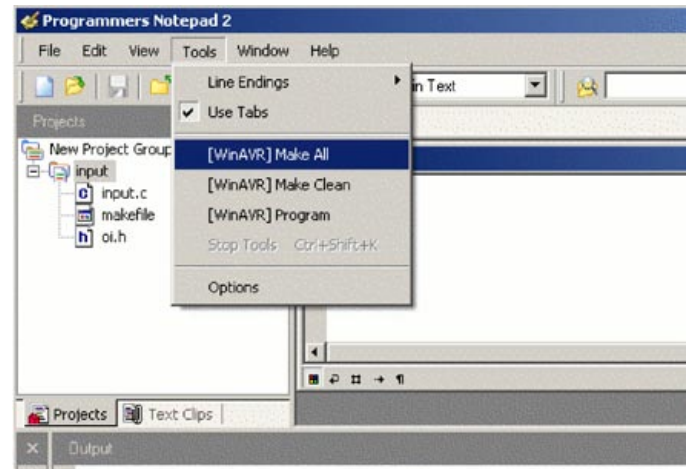

In Programmers Notepad, double-click on one of the source files that you added to open it.

Click on **Tools->[WinAVR] Make All**. Text will appear in the output window at the bottom of Programmers Notepad showing the results of your compilation.

This output window will also list any errors and the line numbers where they occur in your files. You should not get any errors with the provided example programs, but errors may occur as you develop your own code. If there are any errors, fix them and compile again.

You can edit your text files in Programmers Notepad (see the File menu), or you can use any other text editor to change your files and just use Programmers Notepad to compile and download your projects.

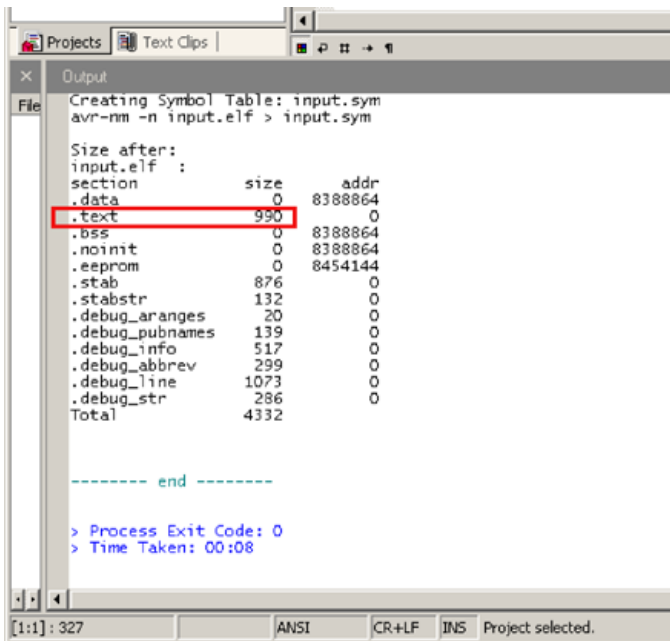

When your compilation is successful, the size of your compiled file in bytes will be listed toward the bottom of output window on the line labeled `.text` (outlined in the picture above - your statistics may be slightly different). The maximum size program that fits in the Command Module's flash memory is 14336 bytes (7168 words). The top 1024 words of the flash memory are taken up by the bootloader and can't be used.

When your compilation is successful, it creates a hex file (`input.hex` in this case) in your project directory that you can load into the Command Module.

Sometimes, when developing your own code, the compilation may not work even though you think it should. To make sure that no intermediate files generated by the compiler are causing a problem, click on **Tools->[WinAVR] Make Clean**, and then try compiling again.

3.4 Downloading your project over the USB link

The next step is to download your compiled hex file into the Command Module. Before downloading, check that:

- The Command Module is turned on.
- You have pressed RESET on the Command Module to force it to run its bootloader.
- There is a full set of charged batteries in Create.
- Create is turned on and its Power LED has stopped flashing.
- Create's serial cable is not plugged in.
- The Command Module is securely seated on Create cargo bay connector.
- The Command Module is connected to your computer with the supplied USB cable and you have installed the USB serial port drivers as described in 2.4.
- The COM port of your Command Module matches the COM port listed in the makefile. The example programs assume you are using COM9. If you installed your Command Module on a different port number, update your makefile. Open the makefile in a text editor and search for where the variable `AVRDUDE_PORT` is set (on line 204 in the *input* project makefile). Change the value from COM9 to your desired port number, for example:

```
AVRDUDE_PORT = com4 # programmer connected to
serial device
```

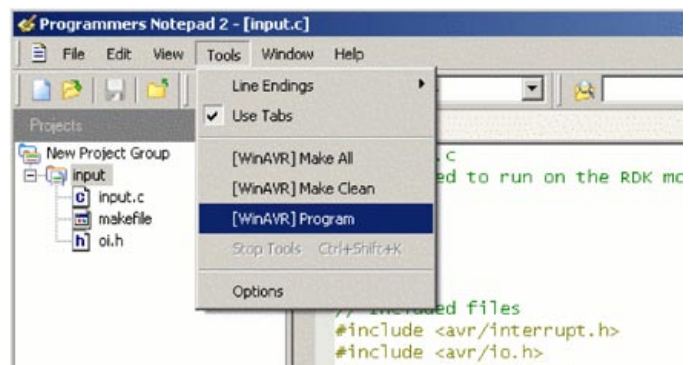

TIP: If avrdude says “cannot find the file specified”, check that you have the correct COM number, and check all connections.

TIP: If avrdude says “not in sync: resp=0x00”, press reset before downloading.

! Always press Reset on the Command Module before downloading.

Press the **RESET** button on the Command Module with the USB cable attached to start the bootloader.

In Programmers Notepad click on **Tools-> [WinAVR] Program**. This starts the downloading program “avrdude”. It communicates with the Command Module’s bootloader to erase the Command Module’s flash memory and then write in your new program. This process can take up to a couple of minutes for a large program.

Avrdude outputs its status in the debug window as it erases the memory and then writes and verifies your new program. On successful completion, you will see text similar to the following toward the bottom of the text in the debug window:

```
avrdude: verifying ...
avrdude: 2118 bytes of flash verified

avrdude done. Thank you.
```

If it doesn’t successfully program, and you get an error message similar to the ones listed below, follow the suggestions that follow to fix the problem and try again.

```
avrdude -p ATmega168 -P com9 -c stk500
-U flash:w:input.hex

avrdude: ser_open(): can't open device "com9":
The system cannot find the file specified.
```

- Make sure Create has a full set of charged batteries.
- Make sure that the Command Module is securely seated in Create.
- Make sure that the USB cable is firmly plugged into both the Command Module and your computer.
- Make sure that the COM number of the Command Module matches the com number listed in your makefile.
- Make sure that you installed the USB serial port for your Command Module as described in chapter 2.
- Make sure that no other device is using the COM number in the makefile.

```
avrdude -p ATmega168 -P com9 -c stk500
-U flash:w:input.hex

avrdude: stk500_getsync(): not in sync: resp=0x00
```

- Make sure Create has a full set of charged batteries.
- Make sure that the Command Module is securely seated in Create.
- Make sure that the USB cable is firmly plugged into both the Command Module and your computer.

- Press the reset button on the Command Module, being sure not to press the soft button at the same time.

```
avrdude -p ATmega168 -P com9 -c stk500
-U flash:w:input.hex
```

...but then nothing happens.

- Make sure that the USB cable is firmly plugged into both the Command Module and your computer.
- Press the reset button on the Command Module, being sure not to press the soft button at the same time.

3.5 Testing the “input” example program

Remove the USB cable from the Command Module. Make sure Create’s serial cable is not plugged in. Press the red Reset Button on the Command Module to start your program.

When the input program starts, two LEDs should flash slowly, one on the Command Module and one on Create itself.

Press the Play button on Create. It will play a song and light the Advance LED on Create solid while the song is playing.

Press the soft button on the Command Module. Create plays a different song and the LED on the Command Module stays lit while it’s playing.

There are three different input/output methods you can use in your programs, two of which you’ve just seen. First, you can read the state of Create’s buttons and other sensors and set the state of its LEDs and motors using the Open Interface serial protocol. Next, you can interact with the Command Module’s built-in hardware by reading the state of the soft button or controlling LED 1 and LED 2 on the Command Module. Finally, you can add your own hardware for input and output. The next chapter will walk you through adding another button and LED to one of the Command Module’s input/output (I/O) ports and interacting with them with the input program.

A note on starting programs. Normally, if the USB cable is inserted in the Command Module when you press the reset button, the Command Module runs its bootloader and does not start your program. To run your program without first removing the USB cable, press and hold down the programmable button on the Command Module as you press the reset button.

TIP: To run your program with the USB cable attached, hold down the soft button while pressing the reset button.

3.6 Creating your own project

The easiest way to start a project is to copy one of the example programs and modify it for your own application. For instance, the framework for sending commands and reading sensors provided by the drive example can be useful for most applications. To create your own project based on the drive example, perform the following steps:

1. Copy `drive.c`, `oi.h`, and `makefile` from the drive example directory over to your new project directory.
2. In the new directory, rename `drive.c` to the desired name for your new program, such as `myapp.c`
3. Edit the `makefile` to reflect the new name of your application. Specifically, you need to change the value of `TARGET` to the name of your new application. On line 59 of the drive `makefile`, you'll see the line:

```
TARGET = drive
```

Change this to the new name of your application.
For instance:

```
TARGET = myapp
```

Next, change the behavior of the program to suit your new application by changing the C code. In `drive.c`, the behavior of Create is defined in the `main` function. Refer to chapters 5 and 6 for examples of the different functionality that you can add. When you're ready with your code, repeat all of the steps in this chapter to set up a project and to compile, download, and test your program.

3.6.0 The example programs

By looking at the source code of the example programs, you can get a sense for the kind of code you can write for the Command Module. Below is a brief description of the three example programs.

3.6.1 Drive

The **drive** example program comes preprogrammed into the Command Module. It demonstrates the basic capabilities of the Command Module and the iRobot Create Open Interface by driving around, reacting to sensors, and using various inputs and outputs. It makes a series of rising beeps when it is first powered to let you know the Command Module is alive and blinks Create's LEDs (note that the program makes Create's power LED orange). Then, if you place Create on the floor and press the Command

Module's soft button it starts driving on the floor, backing up and turning when it runs into something with its bumper, and blinking all LEDs in a pattern. To stop the program, press the button again or simply pick it up.

The code provides useful function to initialize the Command Module and iRobot Create, continuously read Create's sensor values, drive Create, turn on Create, and change the baud rate. You can add capabilities to the main function of the program using the software examples in chapter 5.

3.6.2 Input

The **input** example program illustrates the three types of input and output that you can use with the Command Module. You can interact with hardware on iRobot Create through the Open Interface, use the built-in Command Module hardware, and add your own hardware to the Command Module's connectors.

This simple program flashes three LEDs, one on each type of output, and waits for button presses on each type of input. If it gets a button press, it lights the associated LED and plays a song.

Add your own button and LED, as described in chapter 4, and try using all three types of input and output.

3.6.3 Light

The **light** example program demonstrates a possible application for the Command Module and iRobot Create. It searches your house for lights which are left on and plays an alarm when it finds a light so that you can turn it off. The program has all of Create's and Command Module's LEDs turned on (note that Create's power LED will be orange) so that it's easy to find in the dark.

Start it up in a relatively dark room by pressing the soft button. It will sample the light level when it starts and will set off its alarm when it detects a significantly brighter room.

To detect the light level, the program uses a CDS light sensor which you need to add to the Command Module's top center ePort, as described in section 4.12. It measures the light level from the sensor using one of the Command Module's analog input pins.

4 Software Reference

This chapter gives code examples and explanations of how to control some of the Command Module's hardware. For full details on the ATmega168's registers and features, please see the ATMeta168 datasheet, included on the product CD.

4.1 Declaring and using variables and registers on the ATmega168

The processor in the Command Module is an Atmel ATmega168 8-bit microcontroller. All of the operations on the processor are carried out with 8-bit registers (as opposed to the 32-bit registers in most home computers). For efficiency, use 8-bit variables and calculations wherever possible, only using 16-bit variables wherever their greater range is really necessary.

Do not use floating point numbers or division in your Command Module code. The ATmega168 doesn't have hardware to handle floating point numbers or divide operations. If you use these, your compiled code gets big very fast. Instead, use integers, and use right shifts (>>) instead of divides.

The example programs use explicit type notation so that you can easily tell the size of a variable. This notation is recommended for all of your own code. The example code declares variables with the following types:

```
uint8_t variable_a; /* unsigned 8-bit variable */
int8_t variable_b; /* signed 8-bit variable */
uint16_t variable_c; /* unsigned 16-bit variable */
int16_t variable_d; /* signed 16-bit variable */
```

To use these variable types, include the `stdlib.h` file at the beginning of your program:

```
#include <stdlib.h>
```

The microcontroller's built-in registers (e.g. `DDRB`, `PORTC`, `PIND` referenced below) are all declared in header files which are installed with WinAVR. Include the following line at the beginning of your program:

```
#include <avr/io.h>
```

This header also declares the bit value for all named bits in the ATmega168 datasheet. So, you can use lines like the following in your code:

```
UCSR0B |= (1 << RXEN0); /* Set the RXEN0 bit in
UCSR0B */
```

To make it even more convenient, you can use the bit value macro `_BV` as shown below:

```
UCSR0B |= _BV(RXEN0);
```

4.2 I/O Pin Basics

The Command Module gives you direct access to the Atmel ATmega168 microcontroller's input/output (I/O) pins, so you can add any control signals, sensor drivers, or communication protocols necessary to interface with your external hardware.

The following sections explain how to use the I/O pins and then gives an example of adding an extra button and LED to the *input* example program. Another section explains how to use an analog input to measure the voltage of a *light* sensor using the light example program.

The Command Module provides digital input and output pins, as well as analog input pins. The Command Module uses 5V logic and a 5V reference for the analog inputs.

Full technical details on the Command Module's Atmel ATmega168's I/O pins and registers can be found in the microprocessor reference manual, included on the CD.

4.3 The Command Module's connectors

The microcontroller's I/O pins are connected to the Command Module's four ePorts. There are three ports on the top and one on the side facing the cargo bay. The top three connectors are positioned so that you can attach sensors on the right, left, and center and compare their values to steer the robot.

TIP: If you attach a light sensor to the analog input of each top connector, you can program iRobot Create to follow a flashlight by turning toward the sensor that receives the most light.

The Cargo Bay ePort has extra I/O lines for Create's Low Side Drivers, which you can use to run motors without any additional hardware. For a complete list of all of the Command Module's I/O and connectors, refer to the Hardware reference section in chapter 9.

Some of the I/O pins are connected to the Create CargoBay Connector, located on the underside of the Command Module.

4.4 The Digital I/O control registers

The Command Module’s ATmega168 microcontroller has three I/O ports, labeled B, C, and D. Each of these ports contains 8 pins, numbered 0 to 7. The Command Module’s ePorts expose pins B 0-3 and C 0-5. See the Hardware Reference in chapter 8 for a table of which microcontroller pins are connected to which ePort pins.

The digital I/O pins on each port are controlled and accessed by three built-in registers per port. You need to set the value of some of these registers before using the I/O pins. The registers are predefined as 8-bit variables in the <avr/io.h> header file which is installed with WINAVR.

The I/O registers are summarized in the table below and more information on setting their values is included in the sections that follow.

DDRB	Port B direction register. Bit values: 0 = input, 1 = output.
DDRC	Port C direction register. Bit values: 0 = input, 1 = output.
DDRD	Port D direction register. Bit values: 0 = input, 1 = output.
PORTB	Port B data register. Output bit values: 0 = low, 1 = high. Input bit values: 0 = pull-up disabled, 1 = pull-up enabled.
PORTC	Port C data register. Output bit values: 0 = low, 1 = high. Input bit values: 0 = pull-up disabled, 1 = pull-up enabled.
PORTD	Port D data register. Output bit values: 0 = low, 1 = high. Input bit values: 0 = pull-up disabled, 1 = pull-up enabled.
PINB	Port B input register. Bit values: 0 = pin is low, 1 = pin is high.
PINC	Port C input register. Bit values: 0 = pin is low, 1 = pin is high.
PIND	Port D input register. Bit values: 0 = pin is low, 1 = pin is high.

4.5 DDRx: Setting the direction of a pin

Register: DDRx

0 = input

1 = output

The DDRx registers (substitute B, C, or D for the x) control the direction of the eight pins in a port. If the bit associated with the pin is set to a 0, then that pin is an input (for example, a sensor or button); if it’s a 1, then it’s an output (for example, a motor or LED). These registers must be set before using the PORTx and PINx registers.

Example: Set pins C0 – C2 as inputs and C3 – C7 as outputs:

```
DDRC = 0xF8;
```

The hexadecimal (hex) value 0xF8 = 11111000 in binary, so the most significant 5 pins (C3 – C7) become outputs.

4.6 PORTx: Setting pullups on an input pin

Register: PORTx

0 = pull-up disabled

1 = pull-up enabled

```
DDRD = 0x01; // enable pull-up on pin B0 only
```

For an input pin, a bit value of 1 in the PORTx register enables a pull-up on that pin; a bit value of 0 disables the pull-up. If the pin is an input with the pull-up enabled, it is guaranteed to be in the high state if it is not being driven low by external hardware. If the pull-up is not enabled on an input pin and it is not being driven, then the pin is considered to be floating and you can’t depend on it being in a specific state.

4.7 PORTx: Setting the state of an output pin

Register: PORTx

0 = low (0 volts)

1 = high (5 volts)

```
DDRB = 0x10; // set pin B4 (already an output) to high
```

The PORTx register sets the state of an output pin, either high or low. If the pin’s bit is set as a 0, then that pin will be low (0 volts); if it’s a 1, then it will be high (5 volts).

Note that when a pin is an output, the PORTx register specifies its state, but when it is an input, the PORTx register specifies whether its pull-up is enabled.

To change the state of one pin at a time while leaving the other states undisturbed, use C’s bitwise operators. Section 4.9 below gives examples of this.

4.8 PINx: Reading the state of an input or output pin

Register: PINx

0 = low (0 volts)

1 = high (5 volts)

The PINx registers are used to read the state of the pins, either high or low. If a pin is low, the associated bit in the register will read as a 0; if it is high, it will read as a 1. You can read the state of a pin whether it is an input or an output.

4.9 Using bitwise operators to selectively change bit values

The C bitwise operators, bitwise-or (|=), bitwise-and (&=), and bitwise-exclusive-or (^=), as well as the not operator (~) should be used to change the value of one bit at a time with these registers. Some examples are below.

The following code sets pin B2 as an output:

```
DDRB |= 0x04;
```

This sets the value of bit 2 to be 1, but doesn't affect the other bits in DDRB. The following code sets pin D7 as an input:

```
DDRD &= ~0x80;
```

This sets bit 7 in DDRB to be a 0 without affecting the other bits.

Once you've set pin B2 as an output, the following code sets its state to high:

```
PORTB |= 0x04;
```

The following code sets pin B2 low:

```
PORTB &= ~0x04;
```

If you just want to flip the state of the pin (low to high or high to low), you can use the bitwise-exclusive-or operator. The following code flips the state of pin B2:

```
PORTB ^= 0x04;
```

To check whether a pin is high or low, read the PINx register and then use the bitwise-and operator to check only the associated bit. The following code branches your code according to the state of pin D7:

```
if(PIND & 0x80) {
    /* if D7 is high, run this code */
}
else {
    /* otherwise, if D7 is low, run this code */
}
```

If D7 was connected to a button, you could use this code to perform different actions depending on whether the button was being pushed.

4.10 Command Module Internal Pins

The Command Module's ePorts only expose pins B0-B3 and C0-C5. See the Hardware Reference in chapter 9 for the details and locations of these pins on the ports. The remaining pins are reserved for the Command Module's own hardware and the Create Cargo Bay Connector on the underside of the Command Module:

Pin	Description	Direction
PB4	Serial port select. 1 = connect serial I/O to USB port. a0 = connect serial I/O to Create	Output
PB5	Create Power Detect. High if Create is on.	Input
PD0	Serial Rx	Input
PD1	Serial Tx	Output
PD2	Create Device Detect Input. Change Create's baud rate to 19200 by toggling this pin 3 times with 200 ms pulses (or use the Baud command - see the Open Interface documentation)	Output
PD3	USB Detect	Input
PD4	Command Module Soft Button	Input
PD5	Command Module LED 1	Output
PD6	Command Module LED 2	Output
PD7	Create Power Toggle. Turn Create on or off with a low-to-high transition.	Output

For these pins, only use the direction stated in the table above. The remaining pins (B6-7, C6-7) are for Command Module internal use only. Their direction is set in hardware and cannot be changed with software.

4.11 Adding a button and LED to the input example program

In chapter 3, you saw that the *input* example program looks for button presses on Create and on the Command Module and plays a song and lights an LED when a button is pressed. The program is also looking for button presses on a top center ePort input pin and setting an ePort output pin to drive an LED.

Buy a standard pushbutton and an LED from one of the sources listed in Appendix A. Solder them onto a male DB-9 connector as shown in Figure 4. The button is connected to pin 3 (B1) and pin 5 (GND), and the LED is connected to pin 2 (C1) and pin 4 (5V), with the flat side toward pin 2 and the longer lead connected to pin 4. This makes the LED active low (lit when low).

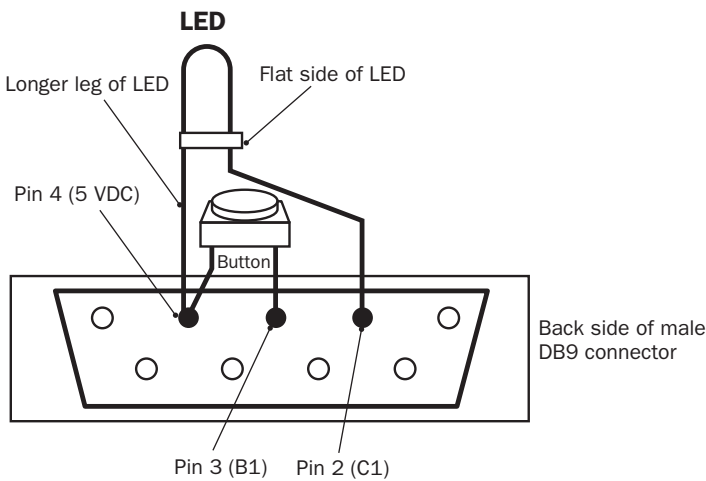

Create Figure 4 Button and LED assembly for the input example program

Plug this assembly into the top center ePort. Install the Command Module in Create. Reload the *input* example program onto the Command Module if necessary and restart it by removing the USB cable and pressing the Command Module’s reset button. You should notice three LEDs flashing, including the one on the assembly you just installed. If you press the button on your assembly, the *input* program will light the LED solid and play a third song.

4.12 Taking an analog measurement using the ADC

The I/O pins on PORTC of the Command Module can be used to take analog measurements with the processor’s 10-bit Analog-to-Digital converter (ADC). For full details on the ADC, see the “Analog to Digital Converter” section of the processor datasheet, included on the Product CD.

The 10-bit ADC uses a 5V reference, so the result of an analog measurement on the Command Module is an unsigned 10-bit number with a value from 0 to 1023, representing input voltages from 0 V to 5 V. For instance, an input voltage of 1 V gives you an ADC reading of 205 according to the formula:

$$\text{ADC reading} = \text{Vin} * 1024 / \text{Vref} = 1 \text{ V} * 1024 / 5\text{V} = 205$$

To take an analog measurement, you need to set up the ADC, start the measurement, and then store the result when it is done. Each of these operations uses registers which are predefined in the WINAVR environment in the <avr/io.h> header.

1. Set up the ADC. The following code uses predefined registers to set the processor up to take analog measurements on pins C4 and C5 (located on pin1 of the Cargo Bay and top center ePorts respectively):

```
DDRC &= ~0xC30; /* set C4, C5 as inputs */
DIDR0 |= 0x30; /* disable digital input on C4, C5 */
PRR &= ~0x01; /* disable ADC power reduction */
ADCSRA = 0x87; /* enable ADC, prescale = 128 */
ADMUX = 0x40; /* set voltage reference */
```

The first line above sets up pins C4 and C5 as inputs. The second line disables the digital inputs on these pins to save power when you only want to use them as analog inputs. The third line turns off a power-saving feature that can’t be used when using the ADC. The fourth line enables the ADC and sets the ADC prescaler to a value of 128 in order to slow down the clock that controls the ADC so that it functions properly while still allowing the main processor to run at a faster frequency. The last line sets up the voltage reference to be the internal processor pin AVcc, which is 5V in the Command Module.

The next step is to set up some variables to store the result of the measurements. The following code declares two 16-bit variables (needed to store the 10-bit ADC results):

```
uint16_t meas_c4;
uint16_t meas_c5;
```

2. Select the channel as C4 and take the first measurement:

```
ADMUX &= ~0x0F; /* clear the ADC channel */
ADMUX |= 0x04; /* set the ADC channel to C4 */
ADCSRA |= 0x40; /* start the ADC measurement */
while(ADCSRA & 0x40); /* wait until it's done */
meas_c4 = ADC; /* save the result */
```

The low 4 bits of the ADMUX register let you select which pin to read from (C0 – C7). So the first two lines of the code clear the ADC channel and then set it to a value of 4 for pin C4. The third line sets bits 6 in ADCSRA, which starts the ADC measurement. The while loop on the next line waits until the measurement is complete by watching the ADSC bit in the ADCSRA register, which goes to 0 when the measurement is done. The 10-bit result is then stored in a 16-bit variable on the last line. ADC is a predefined 16-bit register.

Now, to take a measurement on pin C5, repeat the process with the channel set to 5:

```
ADMUX &= ~0x0F; /* clear the ADC channel */
ADMUX |= 0x05; /* set the ADC channel to C5 */
ADCSRA |= 0x40; /* start the measurement */
while(ADCSRA & 0x40); /* wait until it's done */
meas_c5 = ADC; /* save the result */
```

The 10-bit analog voltage measurements from pins C4 and C5 are now stored in the 16-bit variables and can be used for any calculations or decisions in your program.

The ADC can also be set up to trigger an interrupt when it is complete if you don't want your program to have to wait while taking the measurement. Please refer to the ATmega168 datasheet and the avr-libc documentation for more information on setting up an ADC interrupt.

4.13 Using an analog measurement in the light example program

The **light** example program demonstrates a possible application for the Command Module and iRobot Create. With this program, Create searches your house looking for lights that have been left on so that you can turn them off.

Start it up in a dark room by pressing the soft button. It takes a light measurement when it first starts (to calibrate the sensor) and when it finds an area with significantly more light, it stops and beeps so that you can locate it and turn off the light.

The **light** example program uses the ADC to measure the analog voltage from a CDS light sensor. When more light hits the CDS sensor, you will measure a higher voltage at the ADC input, and vice versa. The example program then uses this information to search for and identify lights left on.

To try the **light** example program, you need to make your own light sensor. Buy a CDS light sensor, a 10 K resistor, and a male DB-9 connector to allow you to easily plug the sensor into the Command Module. Please see Appendix A for several sources where you can buy these components. Once you have the components, assemble them as shown in Figure 5.

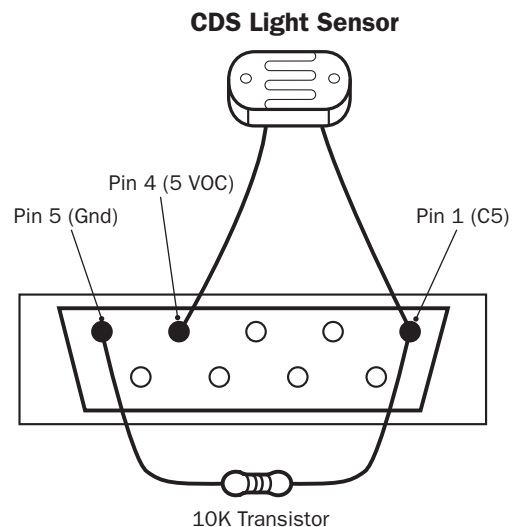

Create Figure 5 Light sensor assembly for the light example program

Your light sensor is now ready to use. Insert it into the top center ePort.

Now, create a new project, build the **light** example program, and download it into the Command Module using the process explained in chapter 3. Download the latest source files from www.irobot.com/create.

Look through the code to see that the program takes one ADC measurement when it first starts in order to set a baseline light measurement. Then, it continuously measures the light level in the main loop of the program while running and compares the current value with the baseline. You can set off the alarm early by shining a flashlight on the light sensor. Try running the **light** example program and changing some of the parameters to see how it changes the behavior.

4.14 Using a timer

You can use timers to control Create's motions, generate signals, or time events. This section will show you how to set up a countdown timer with 1 millisecond (ms) accuracy using one of the ATmega168's timer interrupts. This section assumes basic familiarity with microprocessor interrupts.

The frequency of the processor in the command module is 18.432 MHz.

1. Set up an interrupt to occur once every millisecond. Toward the beginning of your program, set up and enable the timer1 interrupt with the following code:

```
TCCR1A = 0x00;
TCCR1B = 0x0C;
OCR1A = 71;
TIMSK1 = 0x02;
```

The first two lines of the code put the timer in a mode in which it generates an interrupt and resets a counter when the timer value reaches the value of OCR1A, and select a prescaler value of 256, meaning that the timer runs at 1/256th the speed of the processor. The third line sets the reset value of the timer. To generate an interrupt every 1ms, the interrupt frequency will be 1000 Hz. To calculate the value for OCR1A, use the following formula:

```
OCR1A = (processor_frequency / (prescaler *
interrupt_frequency)) - 1
OCR1A = (18432000 / (256 * 1000)) - 1 = 71
```

The fourth line of the code enables the timer interrupt. See the ATmega168 datasheet for more information on these control registers.

2. Declare variables to store the current count of the timer and also a flag variable to let you know when the time has expired. The timer counter should be a 16-bit variable to allow you to specify longer times (up to 65.535 seconds). You can use this variable to determine when a certain number of interrupts have elapsed. Declare the variables with the following code:

```
volatile uint16_t timer_cnt = 0;
volatile uint8_t timer_running = 0;
```

3. Define the actual interrupt handler function code. This code will get called by the microcontroller once per millisecond as specified by the timer registers above.

```
SIGNAL(SIG_OUTPUT_COMPARE1A)
{
    if(timer_running)
    {
        if(timer_cnt)
            timer_cnt--;
        else
            timer_running = 0;
    }
}
```

The first line declares that this is the handler function for the timer1A compare interrupt in the form that the AVR compiler expects. See the avr-libc documentation that came with WinAVR for information on how to declare other types of interrupt handlers. The body of the interrupt checks to see if the timer is running, and if it is running it reduces the timer counter by 1. When the timer counter has counted down to 0, it sets the timer_running variable to false (0).

You can now put timed delays into your Command Module programs. The following code allows you to do something for 2 seconds and then stop:

```
timer_cnt = 2000;
timer_running = 1;
while(timer_running)
{
    /* add code here to do something while you wait */
}
```

The first line of the code sets the counter to 2000 which sets the delay time to 2000 ms or 2 seconds. The second line sets the timer_running flag variable to true (1) so that you can then watch it in a while loop on the third line. When the flag variable becomes false, you know that the time has elapsed. You can add code in the body of the while loop to perform while you are waiting for the delay to end.

In some cases, you just want to wait until the delay is over. For that purpose, you can define a simple delay function that just waits for a specified period of time:

```
void delayMs(uint16_t time_ms)
{
    timer_cnt = time_ms;
    timer_running = 1;
    while(timer_running) ;
}
```

This delayMs function above is used in the included software examples.

4.15 Debouncing a Button Input

In some cases you'll want to filter the digital inputs instead of using them directly. The filtering will depend on the specifics of the hardware connected to the input but one common example is debouncing a button. When a button directly connected to an input pin is pressed, the input signal will often "bounce" between high and low before settling down into the correct state. This can be a problem, particularly if you are counting the number of button presses. Instead of counting every transition, you only want to consider the button as pressed once it has settled down. To add this type of filtering to the button, you'll want to keep sampling the input periodically and only consider the button pressed once it has been in the pressed state continuously for a certain number of samples. For a button input, debouncing for 50 milliseconds (ms) is plenty of filtering.

1. Toward the beginning of your program, set up the input pin (B1 in this example) and declare the variables needed. Connect the button between B1 and ground. Then when the button is pressed, B1 will go low.

```
uint8_t button_pressed = 0;
uint8_t button_cnt = 0;

DDRB &= ~0x02; /* make B1 an input */
PORTB |= 0x02; /* activate B1 pull up*/
```

2. Add the following code in your program where you are looking for a button press. It will debounce the button for 50 ms:

```
button_pressed = 0;
while(!button_pressed)
{
    if(PINB & 0x02) /* check the button */
        button_cnt = 0; /* if not pressed */
    else
        button_cnt++; /* if pressed */

    if(button_cnt >= 50)
        button_pressed = 1;

    delayMs(1);
    /* delay for 1 ms using timer function */
}
```

The code above waits in a while loop, counting the number of times that the button input is low. Since there is a 1ms delay in the loop, each increment of button_cnt represents 1 ms of time. Section 4.14 describes how to implement the delay functionality.

When button_cnt reaches 50, the input has been continuously low for 50 ms and can be considered "pressed". If the button is ever high, the counter is reset so that the debouncer will reject any short pulses. You can add this or similar code to your programs to ensure reliable button input.

4.16 Setting up and using the serial port

To control Create, you communicate with it through the Open Interface serial protocol. In order to do that, you need to set up and use the Command Module's serial port.

Note that Create requires that data sent at its highest baud rate (115200) be sent a minimum of 200µsec apart.

This requires using registers that are defined in the `<avr/io.h>` header that is included with WinAVR. See the processor datasheet on the CD for more details on the serial port registers.

1. Configure the serial port at the beginning of your program. The following code sets up the serial port to communicate at 57600 baud:

```
UBRR0 = 19;
UCSR0B = 0x18;
UCSR0C = 0x06;
```

The first line of the code above selects the baud rate according to the formula:

```
UBRR0 = (processor_frequency / (16 * baud_rate)) - 1
UBRR0 = (18432000 / (16 * 57600)) - 1 = 19
```

Also see "Changing the baud rate," below. The second line enables the transmit and receive functions of the serial port and the third line selects 8-bit data.

2. To send a value over the serial port use code such as:

```
while(!(UCSR0A & 0x20)) ;
UDR0 = 128;
```

The first line above waits in a while loop until the serial transmit buffer is empty, and the second line loads the value to be sent (128, in this example). These operations can be combined into a function named `byteTx` which will be used in the rest of the software examples in this chapter:

```
void byteTx(uint8_t value)
{
    while(!(UCSR0A & 0x20)) ;
    UDR0 = value;
}
```

3. To receive a byte over the serial port, wait for a byte to be available and then read the byte from the serial receive buffer. The following code combines these operations into a function called `byteRx`:

```
uint8_t byteRx(void)
{
    while(!(UCSR0A & 0x80)) ;
    /* wait until a byte is received */
    return UDR0;
}
```

This function will wait until it receives the next byte, so don't call it unless you know a byte is being sent or you could end up waiting forever. You can check if a byte is available with the following code:

```
if(UCSR0A & 0x80)
{
    /* a serial byte is available */
}
```

You can also set up a serial receive interrupt to receive bytes in the background and store them for you to look at later in your program. The **drive** example program uses this method to receive sensor information from the Open Interface. You can copy this functionality by adapting your program from the **drive** example.

4.17 Using the USB Port for Serial Debugging

The Command Module processor only has one UART (serial hardware device), but it can be directed either to the Create connector or to the USB serial connector. Sometimes you may want to debug your program by sending characters to the PC, or sending characters to the module from your PC.

Pin B4 is connected to a device that can switch the UART from Create to the USB connector. Make sure that this pin is always configured as an output. If B4 is high (1), the UART is connected to the USB. If B4 is low (0), the UART is connected to the Create connector. After changing the destination of the UART, wait for at least 10 bit times at your chosen baud rate before attempting to send or receive data. For example, at 57600 baud, wait for at least 10 / 57600 seconds, or 174 microseconds. The following code provides some useful functions for sending characters out of either the USB or Create port:

```
#define USB 1
#define CR8 2
void setSerial(uint8_t com) {
    if(com == USB)
        PORTB |= 0x10;
    else if(com == CR8)
        PORTB &= ~0x10;
}
uint8_t getSerialDestination(void) {
    if (PORTB & 0x10)
        return USB;
    else
        return CR8;
}
void writeChar(char c, uint8_t com) {
    uint8_t originalDestination = getSerialDestination();

    if (com != originalDestination) {
        setSerial(com);
        delayus(200);
    }
    byteTx((uint8_t)(c));
    if (com != originalDestination) {
        setSerial(originalDestination);
        delayus(200);
    }
}
```

4.18 Powering Create

You can turn Create's power on or off through the digital I/O lines of the Command Module. If you have an application that requires long periods of waiting you can turn off Create and just run the Command Module in order to conserve battery power. At a certain sensor event or after a given amount of time, you can turn Create back on and proceed. You can also shut down Create at the end of your programs to avoid draining the batteries.

! Always check that Create is on, and then wait at least 2 seconds for Create to finish running its bootloader before attempting to communicate with Create.

To detect whether Create's power is currently on, set up the Create Power Detect pin (B5) as an input, with the pull-up disabled. If this pin is high, Create's power is on. The following code detects whether Create's power is on:

```
DDRB &= ~0x20; /* make B5 an input */
PORTB &= ~0x20; /* disable pull-up */
if(PINB & 0x20)
{
    /* iRobot Create power is on */
}
else
{
    /* iRobot Create power is off */
}
```

To toggle iRobot Create's power on or off use the Create Power Control pin (D7). The robot's on/off state will toggle whenever there is a low to high transition on D7. The following code detects whether Create's power is on and turns it on if it's not:

```
DDRD |= 0x80; /* make D7 an output */
if(!(PINB & 0x20)) /* if power is off */
{
    PORTD &= ~0x80; /* set D7 low */
    delay(100); /* delay so new state is seen by Create */
    PORTD |= 0x80; /* set D7 high to turn power on */
    delay(100); /* delay so new state is seen by Create */
}
delay(2000); /* Wait for Create's bootloader to run */
```

The 100 ms delays are included in the code above so that fast transitions aren't missed by Create. The following code turns off Create's power:

```
if(PINB & 0x20) /* if power is on */
{
    PORTD &= ~0x80; /* set D7 low */
    delay(100); /* delay so new state is seen by Create */
    PORTD |= 0x80; /* set D7 high to turn power off */
    delay(100); /* delay so new state is seen Create */
}
```

```
PORTC = 0x7F; // enable pull-ups on all C pins
DDRD = 0xEE; // D0 (rx) and D4 (button) are inputs
PORTD = 0x78; // configure D pins
// Put the command module into sleep mode
// These functions are defined <in avr/sleep.h>
set_sleep_mode(SLEEP_MODE_PWR_DOWN);
sleep_mode();
}
```

4.19 Putting the Command Module to Sleep

The Command Module processor has a low-power sleep mode. You can put the module into this mode to conserve power without having to remove it from Create or turn it off. Create's battery power is always available to the Command Module so the Command Module can drain Create's batteries if it is left in the robot. The following code puts the processor into low power mode after first turning off Create, and setting all of the Command Module pins and other hardware into the state that draws the least power:

```
#include <avr/sleep.h>
void powerOff(void)
{
    // If Create's power is on, turn it off using D7
    if(PINB & 0x20)
    {
        PORTD &= ~0x80;
        delay10ms(50); // Delay in this state
        PORTD |= 0x80; // Low to high transition to toggle power
        delay10ms(10);
        PORTD &= ~0x80;
    }
    // Configure pins and other hardware for minimum power
    wdt_disable(); //disable watch dog timer
    ADCSRA = 0x00; //disable the ADC
    UCSR0B = 0x00; //disable UART
    cli(); //disable interrupts
    PRR = 0xFF; //enable all power reduction modes
    DDRB = 0x10; //Set b4 as output, other B pins as input
    PORTB = 0x0F; // set ePort pins B0-3 high
    DDRC = 0x00; // set all C pins as input
```

5 Open Interface Reference

For full details on Create's Open Interface serial protocol, see the Open Interface Command Reference at www.irobot.com/create. This chapter gives an overview of some of the features of the Open Interface, along with code examples for using these features.

5.1 Starting the Open Interface

The processor in the Command Module is an Atmel ATmega168 8-bit microcontroller. All of the operations on the processor are carried out with 8-bit registers (as opposed to the 32-bit registers in most home computers). For efficiency, use 8-bit variables and calculations wherever possible, only using 16-bit variables wherever their greater range is really necessary.

! Make sure that Create's Mini-DIN port does not have a serial cable connected, or Create will not receive the serial commands from the Command Module.

After configuring the Command Module's serial port (see section 4.16), start the Open Interface by sending the "startup" and "full" commands to Create, as follows:

```
byteTx(128); /* start opcode */
byteTx(132); /* full opcode */
```

The "start" opcode on the first line turns on the interface and should always be the first thing you send. At this point the OI is in passive mode, in which you can read the sensors, but not send commands. The second line gives you full control over Create and turns off the safety features. If you send the 'safe' command instead (131), Create will be in safe mode and will stop and revert to passive mode if it detects a cliff with its wheel drop sensors or cliff sensors.

5.2 Changing the baud rate

Create starts up with the serial port listening for commands at 57600 baud. With the Command Module, it is recommended to run at a lower baud rate, such as 28800 baud, to ensure that no data gets lost or corrupted. This section shows you how to change the baud rate, both on Create through the Open Interface, and locally on the Command Module.

1. Switch the baud rate on Create by sending the baud opcode followed by the baud code for 28800:

```
byteTx(129); /* baud opcode */
UCSR0A |= 0x40;
byteTx(8); /* baud code for 28800 */
while(!(UCSR0A & 0x40)) ;
```

The second line in the above code sets up a transmit flag and the fourth line waits in a while loop until the flag is cleared. This is necessary so that you don't change the baud rate on the Command Module until you've completely transmitted the serial bytes at the old baud rate.

2. Change the baud rate on the Command Module to match Create using the following code:

```
cli(); /* disable interrupts */
UBRR0 = 39;
sei(); /* enable interrupts */
delayMs(100);
```

The first line above disables interrupts while you change the baud and the third line re-enables them. The second line sets the new baud rate. You can compute the correct value of UBRR0 for the baud you want from the formula:

$$UBRR0 = (\text{processor_frequency} / (16 * \text{baud_rate})) - 1$$

$$UBRR0 = (18432000 / (16 * 28800)) - 1 = 39$$

All of Create's baud codes are also defined as constants in the oi.h header file, included in each of the example programs. The last line of the code above is a 100 ms delay to allow for the baud change to take effect in Create before sending any more serial commands. See section 4.14 of the example programs for details on setting up this delay functionality.

To make it even easier to change the baud rate, a function named "baud" has been included in the **drive** example program which you can use to change the baud rate to any of the available baud codes listed in the Open Interface documentation.

5.3 Controlling Create's LEDs

To control either of the Command Module's two LEDs, set their associated I/O pin. LED 1 is on pin D5 and LED 2 is on pin D6. A low signal turns the LED on and a high signal turns it off. The following code sets up the pin directions and then turns LED 1 on and LED 2 off:

```
DDRD |= 0x60;    /* make D5 and D6 outputs */
PORTD &= ~0x20; /* turn led 1 on */
PORTD |= 0x40;  /* turn led 2 off */
```

The LEDs on Create are controlled through the Open Interface with the four-byte LED control command. Note that the Open Interface must first be in Safe or Full Mode. The states of the Advance and Play LEDs are set by bits 1 and 3 in the second byte and the power LED has its color and intensity set by the third and fourth bytes, respectively. The following code sets the power LED yellow at half intensity and turns on both of the other Create LEDs:

```
byteTx(132); /* Full Mode */
0xA;        /* leds opcode */
byteTx(0x30); /* led bits */
byteTx(32);  /* power led color */
byteTx(128); /* power led intensity */
```

You can try changing the values in the last three lines to see how they change the LEDs and refer to the Open Interface documentation for a complete description.

5.4 Composing and playing songs

You can use Create's Open Interface to define and play songs. You can define up to 16 different songs and play them back at any time and in any sequence. When you define a song you assign it a song number, which you then later use to play that song. You also specify the number of notes in the song and then each note and its length. The notes are specified by MIDI note number and the lengths are specified in multiples of 1/64th of a second. The following code defines song number 3 to be the first seven notes of "Mary had a Little Lamb":

```
byteTx(140); /* song opcode */
byteTx(3);   /* song number */
byteTx(7);   /* song length */
byteTx(71);  /* note 1 number: B */
byteTx(24);  /* note 1 length: 24/64 seconds */
byteTx(69);  /* note 1 number: A */
```

```
byteTx(24); /* note 1 length: 24/64 seconds */
byteTx(67); /* note 1 number: G */
byteTx(24); /* note 1 length: 24/64 seconds */
byteTx(69); /* note 1 number: A */
byteTx(24); /* note 1 length: 24/64 seconds */
byteTx(71); /* note 1 number: B */
byteTx(24); /* note 1 length: 24/64 seconds */
byteTx(71); /* note 1 number: B */
byteTx(24); /* note 1 length: 24/64 seconds */
byteTx(71); /* note 1 number: B */
byteTx(48); /* note 1 length: 48/64 seconds */
```

To play back the song, send the play command:

```
byteTx(132); /* Full Mode */
byteTx(141); /* play opcode */
byteTx(3);   /* song number */
```

You can define all of the songs at the beginning of your program or right before you play them. Note that the Open Interface must be in Full or Safe mode to play a song. For more information about the song interface, including a reference of all of the note numbers that Create can play, refer to the Open Interface documentation.

5.5 Moving Create

The Open Interface drive command to move Create is five bytes long. The opcode is followed by two signed 16-bit values specifying the velocity in mm/s and the radius in mm. Each 16-bit value is sent as two bytes, high byte first. The following code makes Create drive straight forward:

```
byteTx(132); /* Full Mode */
byteTx(137); /* drive opcode */
byteTx(0x01); /* velocity high byte */
byteTx(0x2C); /* velocity low byte */
byteTx(0x80); /* radius high byte */
byteTx(0x00); /* radius low byte */
```

The first line puts the Open Interface in Full Mode. Note that the Open Interface must first be in Safe or Full Mode for the Drive command to work. Combining the value on the third and fourth lines above, you can see that the velocity sent was a 16-bit value of 0x012C = 300, which makes the robot drive forward at 300 mm/s (about a foot per second). The fourth and fifth lines combine to send a radius value of 0x8000, which is the special case value indicating that the robot should drive straight.

The following code makes Create drive backward slowly (100 mm/s) at a radius of 500 mm:

```
byteTx(137); /* drive opcode */
byteTx(0xFF); /* velocity high byte */
byteTx(0x9C); /* velocity low byte */
byteTx(0x01); /* radius high byte */
byteTx(0xF4); /* radius low byte */
```

The velocity value of -100 as a signed 16 bit hex number is 0xFF9C, is sent as the second and third bytes. The radius of 500 becomes 0x01F4 as a 16-bit hex number. Refer to the Open Interface documentation for the details of the drive command, including other special case radius values. The drive example program defines a function called drive which will split up and send the 16-bit values for you so that you don't have to think about the details each time.

5.6 Controlling Create's low-side power drivers

Create includes three low-side drivers, which are high-power output pins that can be used to drive motors or other power-intensive actuators. They are described in more detail in the Create documentation. The three power driver outputs are brought to pins on the Command Module's DB-9 connectors. Low-side driver 0 is brought out to pin 9 on all three of the top ePorts so that you can use it from any of these connectors. Low-side driver 1 is brought out to pin 8 on the Cargo Bay ePort and low-side driver 2 is brought out to pin 9 on the Cargo Bay ePort. This allows you to connect two different actuators to the Cargo Bay ePort and run them in the cargo bay. For details on the power output capacities, see the hardware reference in chapter 8. To control the state of these pins, use the Open Interface's low side drivers command. The following code turns on all three drivers for 5 seconds and then turns them off again.

```
byteTx(138); /* low side driver opcode */
byteTx(0x07); /* all low-side drivers on */
delayMs(5000); /* wait 5 seconds */
byteTx(138); /* low side driver opcode */
byteTx(0x00); /* all low side drivers off */
```

You can also set the low-side drivers to output intermediate voltages using pulse-width modulation (PWM) with the "PWM Low-Side Drivers" command (144). The pwm period is 128. The following code turns on low-side driver 0 at 25%, low-side driver 1 at 50%, and low-side driver at 0% (off):

```
byteTx(144); /* pwm low-side drivers opcode */
byteTx(32); /* low-side driver 0 at 25% of 128 */
byteTx(64); /* low-side driver 1 at 50% of 128 */
byteTx(0); /* low-side driver 2 at 0% of 128 */
```

Note that both of these commands require the Open Interface to be in Full or Safe Mode.

5.7 Sending an Infrared Character

Low-side driver 1 can also be used to send an infrared character in the format that Create recognizes – the same format that is used by the Home Base and Remote Control. Since the Open Interface also provides the value of such characters (see section 5.8), you can use this to allow one Create to communicate with another Create robot. Connect an infrared LED to low-side driver 1 (located on pin 8 of the cargo bay ePort) in the following configuration:

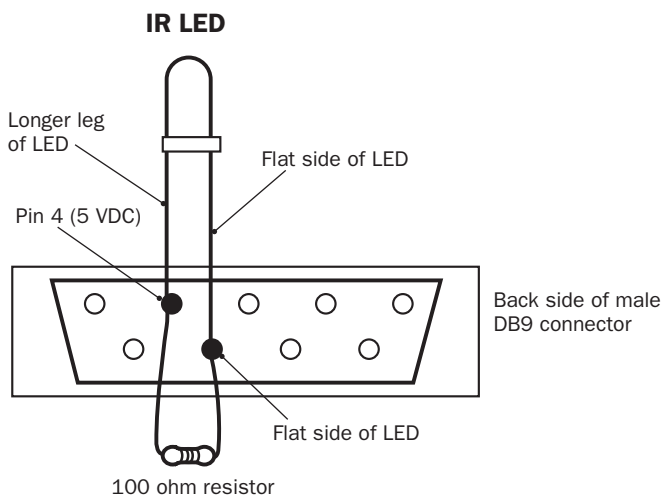

The following code sends the value 20 from the LED that you have connected:

```
byteTx(151); /* Send-IR opcode */
byteTx(20);
```

For more information on this command, including the characters sent by the Home Base and remote control, see the Open Interface manual.

5.8 Reading Create's sensors

Your Command Module program can access all of Create's sensors through the Open Interface with the sensor command. When you send the command, Create will reply with all of the latest sensor information, in the byte order specified in the Open Interface documentation, sending the result out of its serial port.

! Create updates its sensors and replies to sensor requests at a rate of 67 Hz, or every 15 milliseconds. Do not send sensor requests faster than this.

The following code shows how to request the latest sensor information and store it in an array, and then checks to see whether any cliffs are detected:

```
uint8_t i;
uint8_t sensor[26]; /* array for sensor data */

while(UCSR0A & 0x80) /* clear the receive buffer */
    i = UDR0;

byteTx(142); /* sensor opcode */
byteTx(0); /* send request for packet 0 */

for(i = 0; i < 26; i++)
{
    sensor[i] = byteRx(); /* read each sensor byte */
}

if(sensor[2] || sensor[3] || sensor[4] || sensor[5])
{
    /* a cliff is detected */
}
else
{
    /* no cliff detected */
}
```

If you don't need all of the sensor information, you can ask Create to only send you a subset of the data or a single sensor. See the Open Interface documentation for more information about the sensor command and the interpretation of all of the sensor data.

6 Microcontroller Reference

The Command Module is powered by an Atmel AVR ATmega168 microcontroller. All of the code that you run and download to the Command Module runs on this processor. Below is a list of the microcontroller's features, including memory size and fuse setup. For more detailed information on the ATmega168, see the datasheet on the Command Module Product CD. The Command Module comes with a pre-installed bootloader to allow you to easily download your own programs to the Command Module. The bootloader is described in more detail in the "Bootloader reference" section.

Command Module's ATmega168 specifications:

- Architecture: 8-bit RISC
- Crystal frequency: 18.432 MHz = 18,432,000 Hz
- Available Flash memory: 7168 words (14336 bytes)
- EEPROM memory: 512 bytes
- Features:
 - o Two 8-bit timer/counters
 - o One 16-bit timer/counter
 - o 6 PWM channels
 - o 8-channel, 10-bit ADC
 - o One serial UART
 - o SPI interface
 - o 2-wire serial interface
 - o Watchdog timer
 - o Interrupt and wakeup on pin change
- Fuse and lock bits are set to their defaults, except as follows:
 - o Boot Flash section size = 1024 words (BOOTSZ = 00)
 - o Boot Reset vector enabled (BOOTRST = 0)
 - o Brown-out detection level at VCC = 4.3V (BODLEVEL = 100)
 - o Clock NOT divided by 8 (CKDIV8 = 1)
 - o External Crystal Oscillator, Frequency 8- MHz (CKSEL=1111 SUT=11)
 - o SPM not allowed to write to the Boot Loader section (BLB1 mode 2, BLB12:11 = 10)
- Therefore, fuse and lock byte values are:
 - o Extended Fuse = 0xF8
 - o High Fuse = 0xDC
 - o Low Fuse = 0xFF
 - o Lock = 0xEF (read as 0x2F by avrdude)

7 Bootloader Reference

The Command Module comes with a bootloader pre-installed in the Flash memory. The bootloader allows you to download your own programs to the Command Module using Programmers Notepad and avrdude and is capable of updating the rest of the Command Module's memory (Flash and EEPROM).

The following conditions determine whether the bootloader or your program starts up on reset:

- If the USB cable is connected when the Command Module is reset, the bootloader starts up, otherwise your program starts up.
- Any time the USB cable is inserted, the bootloader starts up, even in the middle of running your program.
- With the USB cable connected, if the soft button is held down while you reset the Command Module, your program starts.

The bootloader code is located in the top 1024 words (2048 bytes) of the Flash memory and is code protected so that it can't be accidentally overwritten. The Command Module's ATmega168 microcontroller has a total Flash memory size of 8192 words (16384 bytes). Since the bootloader uses 1024 words, your Command Module programs can be up to 7168 words (14336 bytes) in size. You can also use all 512 bytes of the available EEPROM memory to store parameters and other information for your program that won't get lost with a reset.

The bootloader loads programs using the STK500 version 1 protocol. This protocol is designed into the avrdude downloading software and is selected using the `-c stk500` command line option. Avrdude is called automatically by Programmers Notepad when you download code into the Command Module using the **Tools->[WinAVR] Program** option as explained in chapter 3. If desired, you can run avrdude directly at a command prompt; enter `avrdude -?` at the command prompt to get a list of avrdude command options.

8 Hardware Reference

8.1 ePort Pinouts

The Command Module has a total of four Expansion Ports (ePorts) that allow you to add external electronics to the Command Module. These ports provide:

- 4 analog inputs
- 3 general-purpose input/output pins
- 3 three high-current low-side drivers

The ePorts use a standard female DB9 connector. The following diagram shows the location of the 4 ePorts on the Command Module.

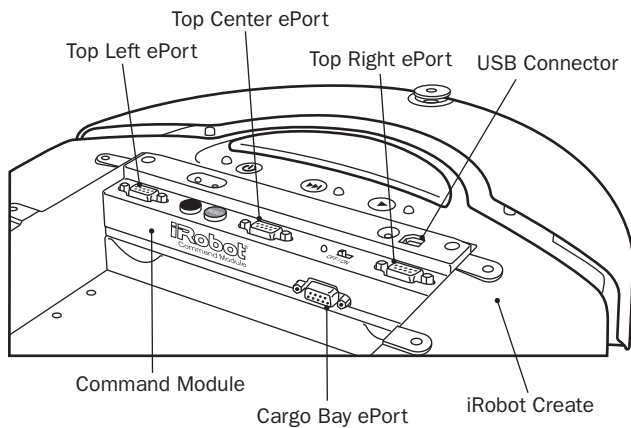

The ePorts have pin number connections as shown in the following diagram. The numbers are shown looking down on to the ePorts.

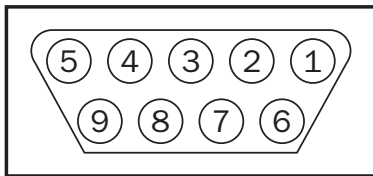

8.2 ePort I/O connections

The tables below show the signal connections for the each of the ePorts. All of the ports have similar electrical connections allowing ePort add-on modules to be installed in any of the ports, depending on your needs. The metal shields and screw jacks on the ePorts are connected to ground.

! The ePorts are not RS-232 serial ports. Do not connect an ePort to a PC.

Top Left ePort

Pin#	Description	Name
1	Analog Input 7	ADC7
2	Digital I/O (Port C pin 3) or Analog Input 4	PC3/ADC4
3	Digital I/O (Port B pin 3)	PB3
4	Regulated 5V voltage (when Create is on)	Vcc
5	Create Battery Ground	Gnd
6	Not Connected	NC
7	Create Battery Voltage (when Create is on)	Vpwr
8	Not Connected	NC
9	Low Side Driver 0	LD0

Top Center ePort

Pin#	Description	Name
1	Digital I/O (Port C pin 5) or Analog Input 5	PC5/ADC5
2	Digital I/O (Port C pin 1) or Analog Input 1	PC1 /ADC1
3	Digital I/O (Port B pin 1)	PB1
4	Regulated 5V voltage (when Create is on)	Vcc
5	Create Battery Ground	Gnd
6	Not Connected	NC
7	Create Battery Voltage (when Create is on)	Vpwr
8	Not Connected	NC
9	Low Side Driver 0	LD0

Top Right ePort

Pin#	Description	Name
1	Analog Input 6	ADC6
2	Digital I/O (Port C pin 2) or Analog Input 2	PC2/ADC2
3	Digital I/O (Port B pin 2)	PB2
4	Regulated 5V voltage (when Create is on)	Vcc
5	Create Battery Ground	Gnd
6	Not Connected	NC
7	Create Battery Voltage (when Create is on)	Vpwr
8	Not Connected	NC
9	Low Side Driver 0	LD0

Cargo Bay ePort

Pin#	Description	Name
1	Digital I/O (Port C pin 4) or Analog Input 4	PC4/ADC4
2	Digital I/O (Port C pin 0) or Analog Input 0	PC0/ADC0
3	Digital I/O (Port B pin 0)	PB0
4	Regulated 5V voltage (when Create is on)	Vcc
5	Create Battery Ground	Gnd
6	Not Connected	NC
7	Create Battery Voltage (when Create is on)	Vpwr
8	Low Side Driver 1	LD1
9	Low Side Driver 2	LD2

Processor I/O Pins

Pin Name	Description	Location
PB0	Digital I/O	Cargo Bay ePort pin 3
PB1	Digital I/O	Top Center ePort pin 3
PB2	Digital I/O	Top Right ePort pin 2
PB3	Digital I/O	Top Left ePort pin 3
PB4	Serial port connector select. 1 = USB port. 0 = Create	Internal
PB5	Create Power Detect. High if Create is on.	Create connector pins 10-13
PB6	Clock line	Internal Use only
PB7	Clock line	Internal Use only
PC0	Digital I/O or Analog Input	Cargo Bay ePort pin 2
PC1	Digital I/O or Analog Input	Top Center eport pin 2
PC2	Digital I/O or Analog Input	Top Right ePort pin 2
PC3	Digital I/O or Analog Input	Top Left ePort pin 2
PC4	Digital I/O or Analog Input	Cargo Bay ePort pin 1
PC5	Digital I/O or Analog Input	Top Center eport pin 2
PC6	Reset Line	Internal Use only
PD0	Serial Rx	Create connector pin 2 or USB
PD1	Serial Tx	Create connector pin 1 or USB
PD2	Create Device Detect Input	Create connector pin 15
PD3	USB Detect	USB port
PD4	Command Module Soft Button	Left button
PD5	Command Module LED 1	Left green LED
PD6	Command Module LED 2	Right green LED
PD7	Create Power Toggle (on rising edge)	Create connector pin 3
ADC6	Analog Input	Top Right ePort pin 1
ADC7	Analog Input	Top Left ePort pin 1

8.3 ePort connection types and interfacing

The ePorts include several different types of connections including ADC inputs, Digital I/Os, low side drivers, and power supply lines. The connections labeled as “Digital I/O or ADC Input” can be configured in software to be either type (see sections 4.5 and 4.12).

The ePorts’ Digital I/O and ADC input lines have the electrical circuit model shown in the following schematic. The connector’s pins are connected to the Command Module’s internal processor through an electrical protection network to protect against electrostatic shock damage.

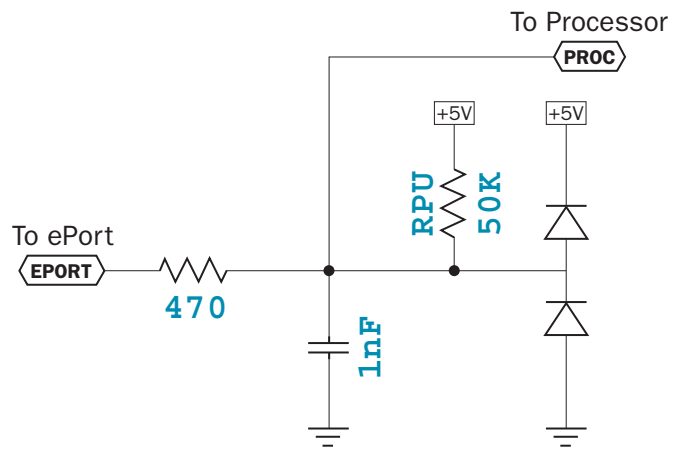

The RPU pull-up resistor shown in the schematics is internal to the processor, and is only available on the Digital I/O lines and not the ADC input lines. It can be enabled or disabled by setting or clearing the appropriate I/O configuration registers.

When configured as an output, the Digital I/O lines are capable of sinking more current than they can source. An output is considered to source current when current follows out of the pin, through an external component and into the ground pin. An output is considered to sink current when current flows out of a positive power supply connection, through an external component, and into the output pin. Generally speaking, outputs source current when they are high and sink current when they are low.

! When controlling devices that require higher currents such as LEDs, always wire them so that the output sinks current as shown in the following example.

Since the Digital I/O lines have built-in resistors as shown in the circuit model above, an external current limiting resistor is not required to drive an LED.

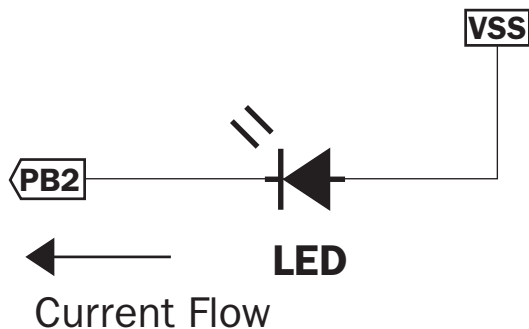

The ePorts also contain three software programmable low side drivers (LDO, LD1, and LD2). LDO is connected to all three of the top ePorts. LD1 and LD2 are only connected to the cargo bay ePort. A low side driver is special type of output which can sink a large amount of current. Low side drivers are useful for controlling a motor or other power device as shown below.

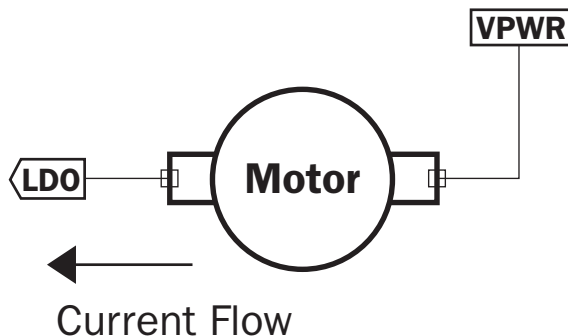

8.4 ePort electrical specifications

The electrical specifications for the signal lines and low side drivers are given in the following table.

Type	Spec	min	max	unit
Analog Input	Voltage In	0	5	V
Digital I/O	Voltage In and Out	0	5	V
	Current Out Low	0	10	mA
	Current Out High	0	2	mA
Low Side Drivers 0 and 1	Voltage Out	0	21	V
	Current Out Low	0	500	mA
Low Side Driver 2	Voltage out	0	21	V
	Current Out Low	0	1600	mA

Each of the ePorts has three power connections: Vcc, Vpwr and Gnd. The ground line serves as digital and analog zero voltage reference. All of the specifications given in this booklet are referenced to the Gnd line. Vcc is the digital power supply line and Vpwr connects to Create’s battery power supply. Both Vcc & Vpwr are switched on and off with Create’s power. The following table gives the specifications for Vcc and Vpwr. Note that the output current specification listed is the total current for all of the ePorts combined.

Supply	Spec	min	nom	max	unit
Vcc	Vout	4.5	5	5.5	V
	Iout			100	mA
Vpwr	Vout	7	16	18	V
	Iout			1500	mA

8.5 ePort safety and cautions

The maximum voltage available on the ePort is 21V. The ePort pins will not shock you if they contact your skin. However, the ePort can supply over 20 watts of electrical power which has the potential to burn you or start a fire in the event of an electrical fault. Only experienced users should attempt to design and build their own circuitry. Prebuilt ePort modules are available from a supplier listed in the Appendix A and are suitable for users who lack the experience to design their own circuitry.

Always use care when wiring custom circuitry to an ePort. Never run your iRobot Create unattended. Always fully test your new designs under close supervision. Always remove the battery from Create or remove the ePort add-on circuitry from Create before handling it. Never touch the circuitry with the power turned on. Enclose your add-on circuitry so it is not inadvertently shorted during operation.

The Vcc and Vpwr supplies are protected by a self-resetting fuse within Create. If you exceed the current ratings, power Create off for 30 seconds to reset the fuse.

8.6 Component Suppliers

RadioShack

www.radioshack.com

800-843-7422

RadioShack has retail stores in most major cities. You can visit their website to find the closest location.

Jameco Electronics

www.jameco.com

800-831-4242

Jameco is an online web retailer that carries all of the required components.

Element Direct

www.elementdirect.com

Element Direct offers a low cost kit of all of the components in addition to easy to use ePort compatible prototyping, sensor and expansion modules.

Component	RadioShack Part #	Jameco Part #
DB-9 Male Solder Tail Connector	276-1537	15747CM
CDS Light Sensor	276-1657	202403
5.0mm Red LED	276-209	334422CM
Push Button Switch	275-1547	164566CM
10K Resistor, 1/4W	271-1335	29912

©2007 iRobot Corporation. All rights reserved.

iRobot, Roomba and Virtual Wall are registered trademarks of iRobot Corporation. Home Base and Create are trademarks of iRobot Corporation.

U.S. Pat. Nos. 6,594,844 6,690,134, and 6,809,490. Other patents pending.